



广州恒宽机械有限公司

**Canton Hostandard Machinery CO., LTD**

www.pocket-spring.com

Email: hostandard@hotmail.com

Mob: 0086-133-1411-7277

Skype: northland99

**袋装弹簧粘胶机 Pocket spring assembler HS-SAM75**

*Photo Details*



可独立开关的喷胶头  
Independent hot melt jets

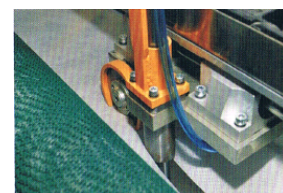

电动上下布裁切装置  
Electronically controlled cutting device for the top&bottom fabric

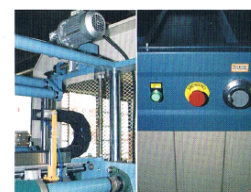

电动粘胶平台升降装置  
Electronically controlled support table for pocket spring unit

video weblink:<http://u.youku.com/northland99>

**Technical Information:**

**Performance 生产效率**

production capacity	生产速度(分钟/张)	5-6mins/unit
---------------------	------------	--------------

**Consumptive Material Specs 耗材参数**

Hot melt glue 热溶胶	Fabric density	胶粒形状	pellent or pieces/粒状或片状
	Viscosity	黏度	125°C-6100cps 150°C-2300cps 175°C-1100cps
	Ring and Ball softening point	软化点	85±5°C
Non-woven fabric 无纺布	Fabric density	布料厚度	65~90g/m <sup>2</sup>
	Fabric width	布料宽度	300-2200mm
	Inner dia.of fabric roll	布辊内径	Min/最小65mm
	Outside diameter of fabric roll	布辊外径	Max/最大600mm

## General Data 一般参数

Mattress Width	床垫宽度	300-2150mm
Air consumption	气源需求量	Approx/约30m <sup>3</sup> /h
Air pressure	工作气压	0.6-0.7mpa
Power consumption in total	总功率	Approx/约6.5KW
Power requirements	Voltage	3AC 380V
	Frequency	50/60Hz
	Input fuse	25A
	Cable section	4×6mm <sup>2</sup>
Working temperature	工作温度	+5℃—+45℃
Weight	重量	Approx/约2450kg

## Output Range 产品规格

		Spring Waist Diameter	Pocket spring height
		弹簧中腰直径 (D)	弹簧入袋后高度 (H)
Standard/常规	A	φ45-φ75	100-250
Special/特殊	S1	φ45-φ75	60-160

## Footprint 占用空间

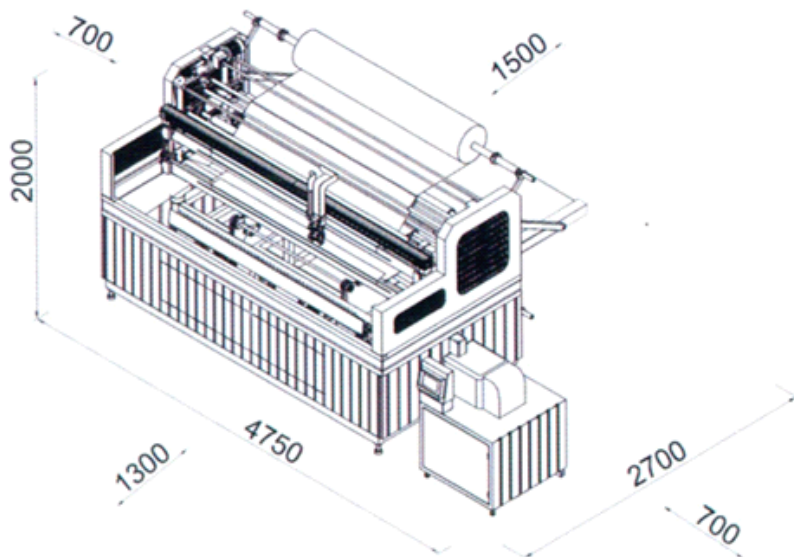

## AFTER-SALE SERVICE 售后服务

## PACKAGING INFO 包装信息

<b>installation:</b>	new machine installation free	<b>packing material:</b>	wood or plywood
	expenditures of way and accommodation paid by customer.	<b>package count:</b>	
		<b>Packing dimensions:</b>	
<b>warranty:</b>	1 year	<b>Volume:</b>	
	free spare parts offered during warranty	<b>gross weight:</b>	
<b>spare parts:</b>	spare parts list offered.	<b>net weight:</b>	

## ADDITIONAL COMMENTS&amp;REMARK

\*Payment terms: T/T 30% deposit in advance, balance 70% 3 days before shipment.

\*Agent policy: in some countries or areas, you can ask our agent for efficient service.